

Side Rail

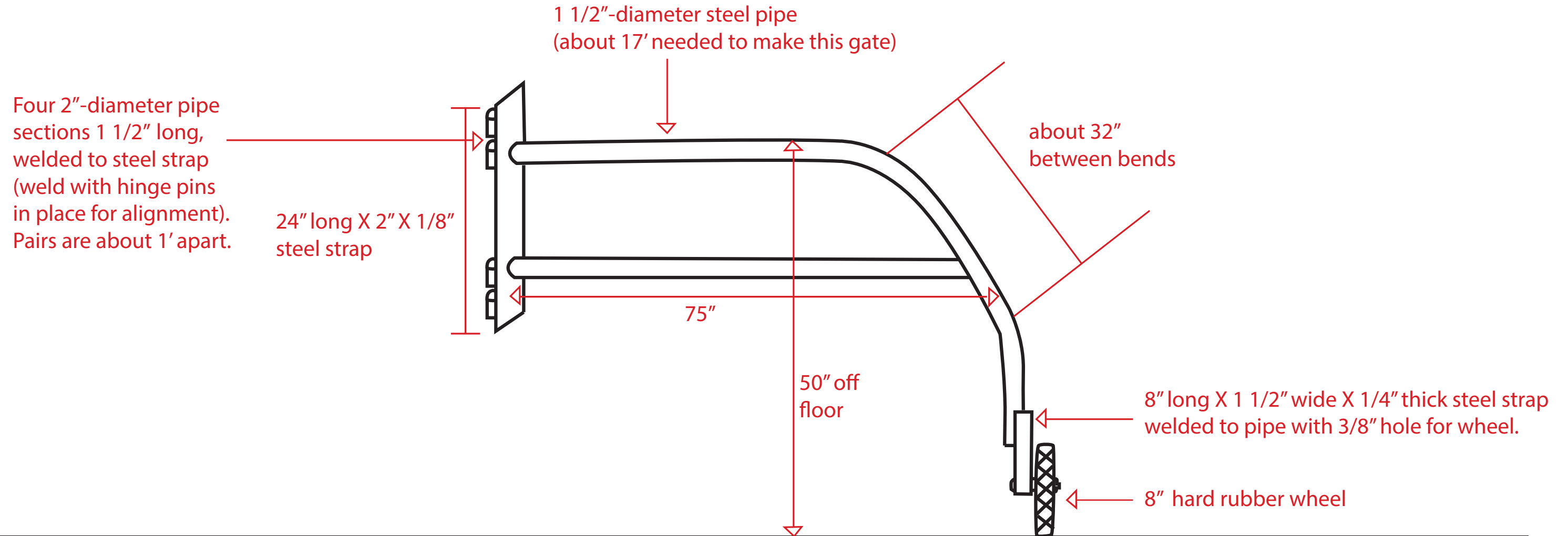

1/8" or 1/4" steel plate with six holes for lag bolts

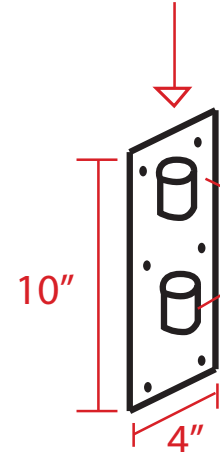

2" steel pipe sections, same assembly as above, welded to plate, spaced and aligned to accommodate hinge pins; 1 1/2" apart

hinge pin



1 1/2" pipe with 2" steel washer welded to top

Supplies List

- two hinge pins: 1 1/2" steel pipe, 7" long
- eight hinge loops: 2" steel pipe, 1 1/2" long
- two 2" steel washers
- one 24" X 2" steel strap
- one 8" X 2" steel strap
- two 4" X 10" steel plates
- twelve lag bolts, 5/16" X 2"
- one wheel bolt
- one 8" hard rubber wheel